

KGK JET CHECKER PK100

KGK presents a compact print inspection system with the affordable price.

Catalog No.9122E

<http://www.kishugiken.co.jp/>

NEW

Simple operation

Compact housing

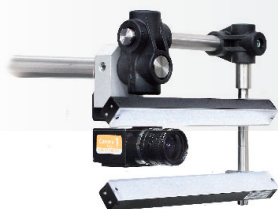

▲ Camera · Illumination · Controller



▲ Inspection display

■ **Equipped with a large size screen**

You might have experienced a complex display for a multiple layered construction.

■ **Reliable print inspection with the simple operation**

Simple setting screen allows an operator to set values using actual measurements got in the bounding box rather than directly inputting values.

■ **Space saving for installation**

You will not be required to install this system into the control board nor to have a separate DC power source.

■ **It provides you to store up to 10,000 images. The highest in this class of inspection systems.**

It provides you to store up to 10,000 images. The highest in this class of inspection systems.

■ **Synchronous operation**

High affinity advantages with inkjet printers with our expertise in inkjet printing technology.

Use of synchronous function would make setting easier time saving as well as help reducing human errors such as incorrect inputting.

● Specifications

Item	Details
Number of items to store	Up to 20
Number of cameras	1
Characters to inspect	Alphanumerical and 30 other characters to store
What to inspect	Verification, missing prints, print positioning, print inclination, missing print, missing dots and density
Number of character for inspecting	Up to 20 for each zone (Up to two zones made available)
Year/month/date/time inspection	Corresponding to KGK inkjet printer models
Character allocation system	Correspond to KGK inkjet printer models
Number of images to save	Up to 60,000 JPEG images
Input/output signals	Input: up to 16 and switchable to banning inspection, etc. Output: up to 12 including Yes/No, in operation, in processing, no continued operation or alarm, etc..
I/O	USB2.0 × 2, RS-232C × 1
Speed	100msec for 10 character in an image depending on other conditions
Power source	AC100-240V ± 10% 50/60Hz 80W
External dimensions	227.9mm(W) × 231.2mm(D) × 165.5mm(H) Requiring some 100mm depth space at back for cable connection
Operational environment	5 to 35°C, 20 to 80% RH (with no dew condensation)

● Dimensions

Controller

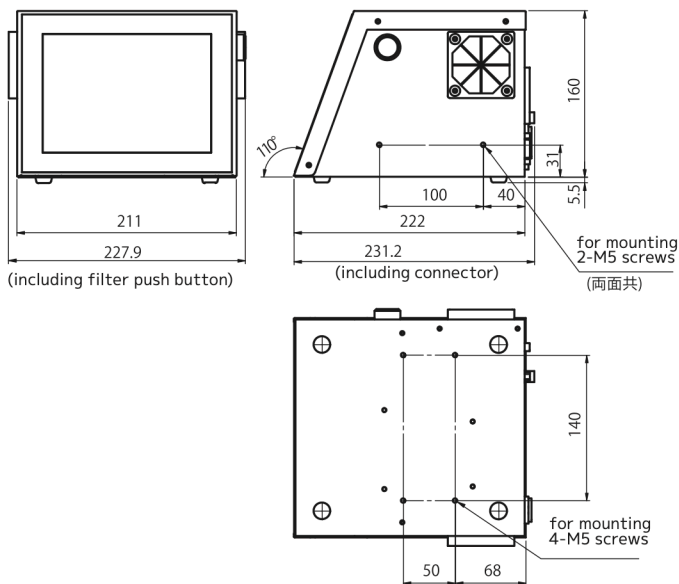

Camera · Illumination

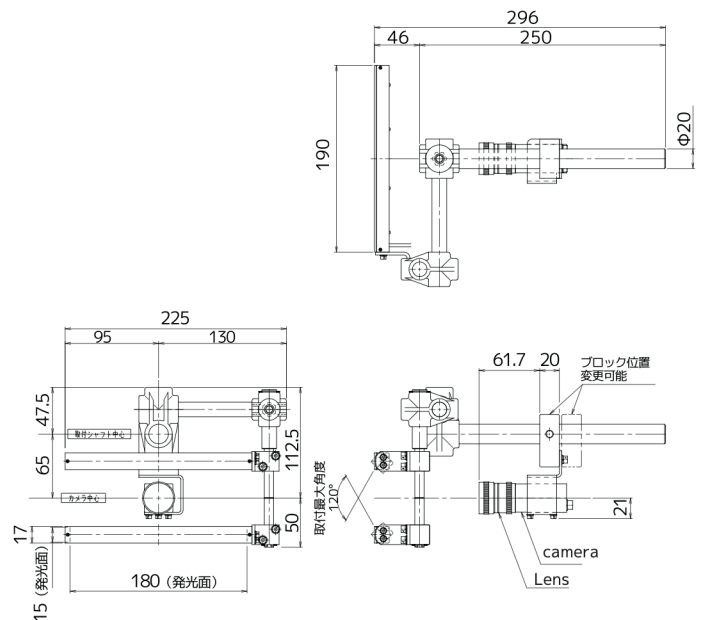

Subject to change without notice.