

YOUGAO 友高

AIMARK Vision Inspection System



AIMARK Vision Inspection System



Product Parameter >>

Type	AIMARK Vision Inspection System (Standard Type)
Main Part (mm)	2650*400/300*900±50
Receiving Part (mm)	1000*300*650-850 (Receiving part screw is adjustable)
Object Size	Length: 70-300mm Width: 70-280mm Thickness: 0.2-5mm
Paging Type	Friction Type
Feeder Part Speed	5-40m/min
Speed Regulation Mode	Variable Frequency Type
Motor Brand	JSCC
Converter Brand	Schneider
Printing Type	Inkjet Printer,Laser Coding Machine,Labeling Machine
Detection Type	NO(Optional)
Printing And Detection Part Speed	5-45m/min
Servo Motor Drive	Schneider fan adsorption+Overlap (One Set)
Accelerate Part Speed	5-85m/min
Rejection Model	Air blow / Flip plate(Optional)
Pneumatic Components Brand	Air TAC
Receiving Type	Automatic Receiving machine
Receiving Part Speed	5-30m/min
Stepper Drive	JNT
Drive Brand	Leisai
PLC/Touch Screen Brand	Schneider
Application	Paper, plastic, metal and other packaging bags, unpacked medicine boxes, cards, labels and other sheet objects,and different types bottle cap

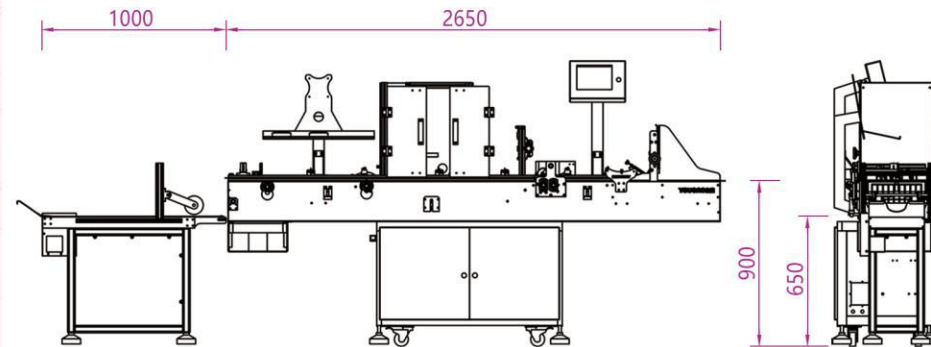
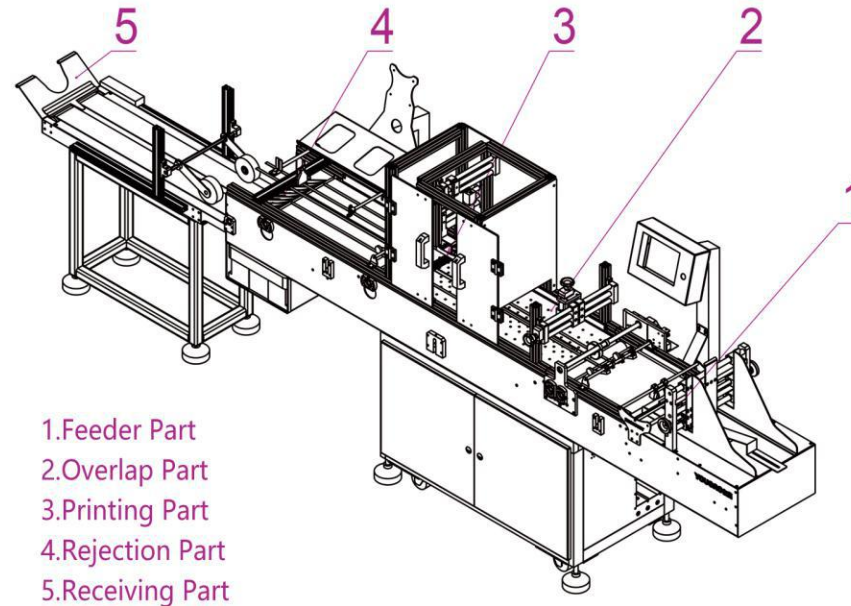

AIMARK Carton Feeder

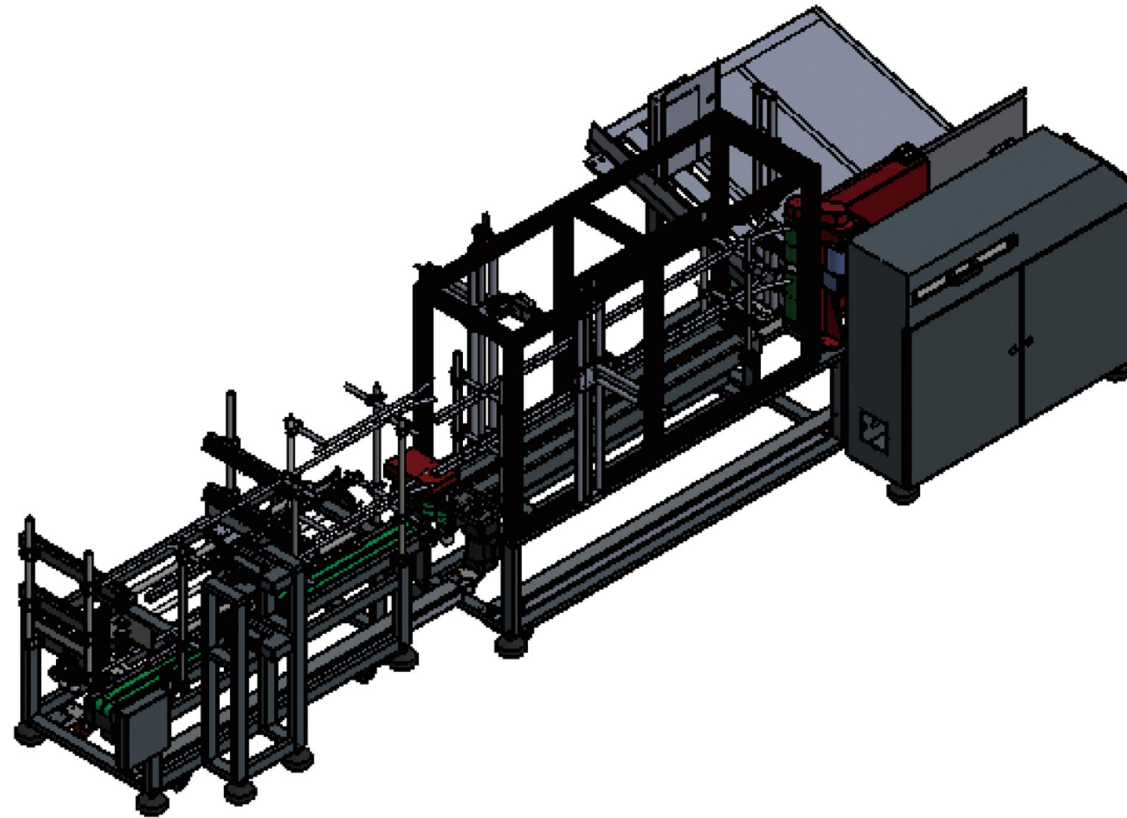

Product Parameter >>

Type	AIMARK Carton Feeder
Size (mm)	4330*1558*963
System Components	Paging Code Part, Automatic Receiving Part, Automatic Rejection Part, Electrical Control Part, Visual Inspection Part
Paging Code Part	a、 Paging mode : stereo type b、 Speed : 5-35m/min c、 Adjustment mode : lead screw adjustment d、 Speed regulation mode : variablefrequency type f、 Coding speed: 15-60m/min
Automatic Receiving Part	a、 Adjustment mode : lead screw adjustment b、 Speed regulation mode : variable frequency type
Electrical Control Part	a、 PLC control, touch screen b、 Within a set of independent electric control box c、 Within a set of display bracket
Visual Inspection Part	OCR, one-dimensional code, QR code, Within or without inspection
Device Configuration	a、 Motor brand : ZD motor b、 Converter brand : Schneider c、 Touch screen, PLC control: Schneider b、 Pneumatic brand : AirTAC e、 Camera brand : YOUGAOSEE f、 Material: Whole machine carbon steel sprayed
Application : corrugated	Length : 400-1100mm Height : 300-1000mm Thickness : 6-25mm

