

# YOUGAO 友高

Traverse Movement System



# Traverse Movement System



## YG-PT03-YD Series Products

X Traverse Movement System



X-Y Traverse Movement System



X-Y-Z Traverse Movement System



## Product Parameter >>

Type	X traverse movement system
Size (mm)	430±50*1000*80
Speed	6.5-40m/min
Main Material	Stainless steel
Moving distance	Equal to the width of machine
Voltage	220V
Power	400W
Control mode	PLC control, Brand Taida
Drive Power	Stepper motor drive, Brand JNT
Speed regulation	Manual screw adjustment
Application	.Suitable for jet head moving coding in the sectors of tubing, sectional materials, cloths, etc., or installed on automatic packaging machine to realize jet head moving coding

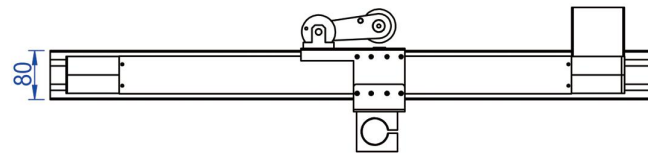
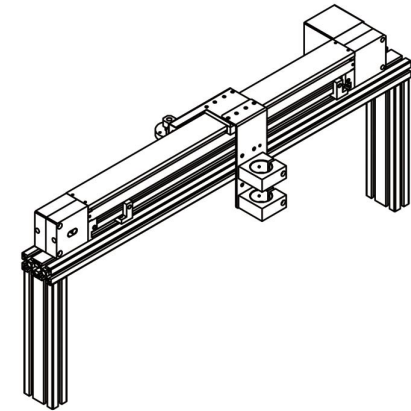
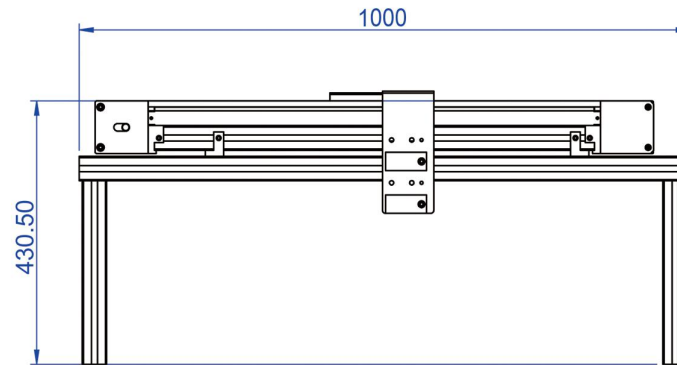

## Product Parameter >>

Type	X-Y traverse movement system
Size (mm)	750*1300*100
Speed	6.5-40m/min
Main Material	Stainless steel
Moving distance	X Direction equal to the width of machine, Y direction customized
Voltage	220V
Power	400W
Control mode	PLC control, Brand Taida
Drive Power	Stepper motor drive, Brand JNT
Speed regulation	Manual screw adjustment
Application	.Suitable for jet head moving coding in the sectors of tubing, sectional materials, cloths, etc., or installed on automatic packaging machine to realize jet head moving coding

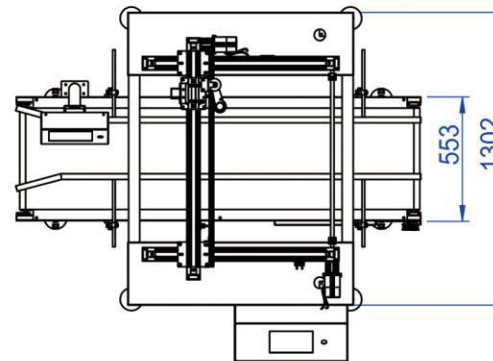
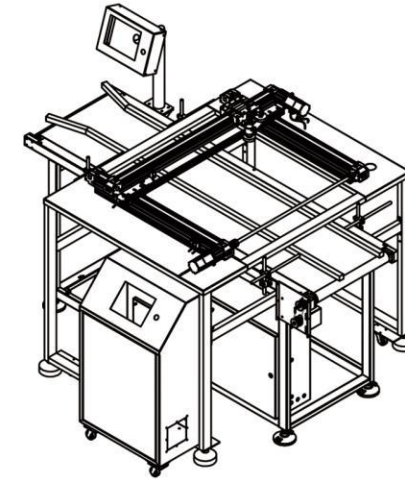
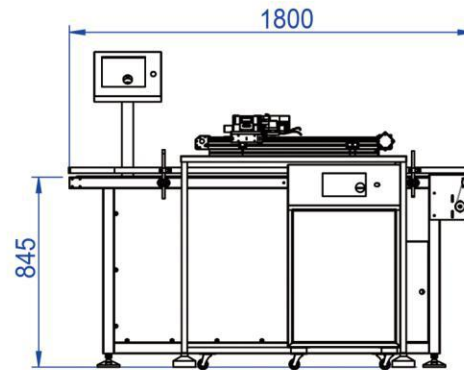

## Product Parameter >>

Type	X-Y-Z traverse movement system
Size (mm)	400*780*1012
Speed	6.5-40m/min
Main Material	Stainless steel
Moving distance	X Direction equal to the width of machine, Y、Z direction customized
Voltage	220V
Power	400W
Control mode	PLC control, Brand Taida
Drive Power	Stepper motor drive, Brand JNT
Speed regulation	Manual screw adjustment
Application	.Suitable for jet head moving coding in the sectors of tubing, sectional materials, cloths, etc., or installed on automatic packaging machine to realize jet head moving coding

