

# YOUGAO 友高

High Speed Friction Feeder



# High Speed Friction Feeder



YG350 Series



## Product Parameter >>

Type	YG 350 (Standard Type)	YG 500 (Widen Type)	YG 350L (Lengthen Type)	YG 500L (Lengthen And Widen Type)
Size (mm)	1420*400/300*725	1420*550/450*725	2000*400/300*725	2000*550/450*725
Separated Object Size (mm)	Length: 60-320 Width: 80-350 Thickness: 0.02-5	Length: 60-320 Width: 80-500 Thickness: 0.02-5	Length: 60-320 Width: 80-350 Thickness: 0.02-5	Length: 60-500 Width: 80-500 Thickness: 0.02-5
Main Material	Stainless steel			
Paging Mode	Friction Type			
Voltage	220V			
Power	180W		250W	
Speed Regulation	Variable Frequency Type			
Converter Brand	Schneider			
Motor	ZIK			
Speed	30-100m/min			
Application	Packing Bags: Plastic bag, paper box, paper bag, label, paper piece, etc Flake goods: Card			

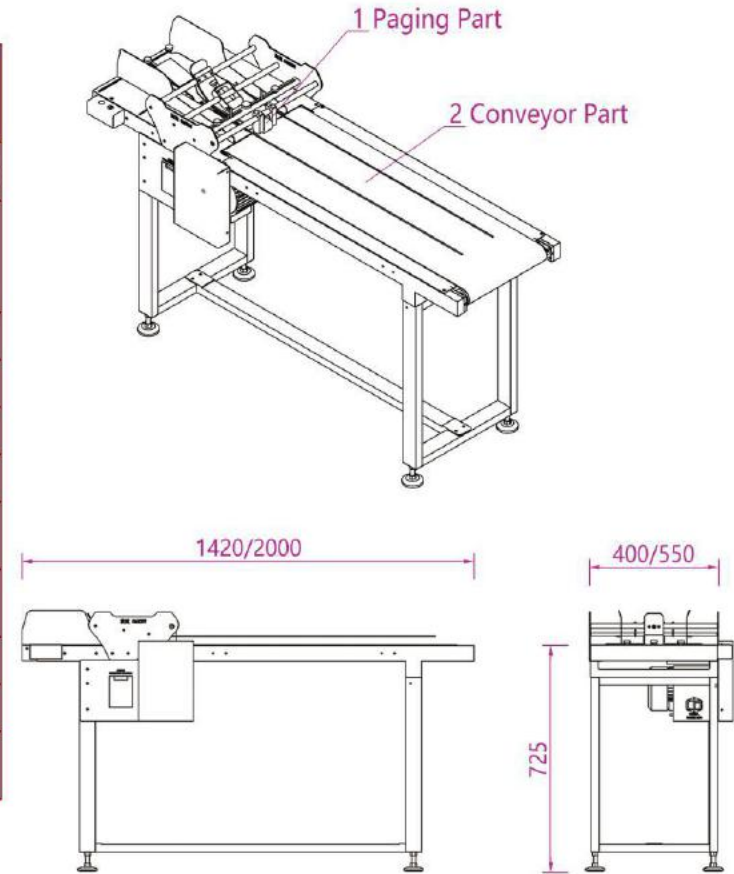

# High Speed Friction Feeder

YG350 Desktop Type

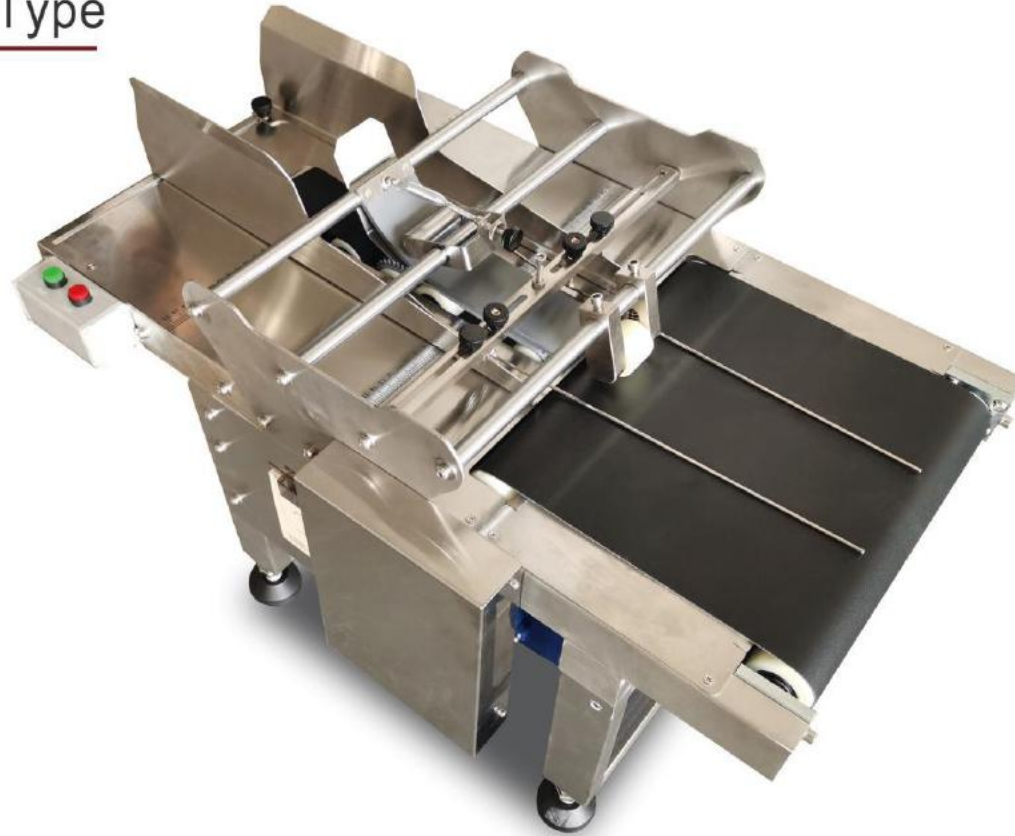

## Product Parameter >>

Type	YG350 Desktop Type
Size (mm)	740*400/350*400mm
Separated Object Size (mm)	Length : 60-320 Width : 80-350 Thickness : 0.02-5
Main Material	Stainless steel
Paging Mode	Friction Type
Voltage	220V
Power	180W
Speed Regulation	Variable Frequency Type
Converter Brand	Schneider
Motor	ZIK
Speed	30-100m/min
Application	Packing Bags:paper box, paper bag, label, paper piece, Card

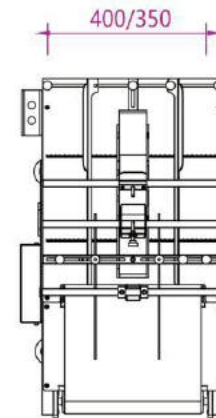
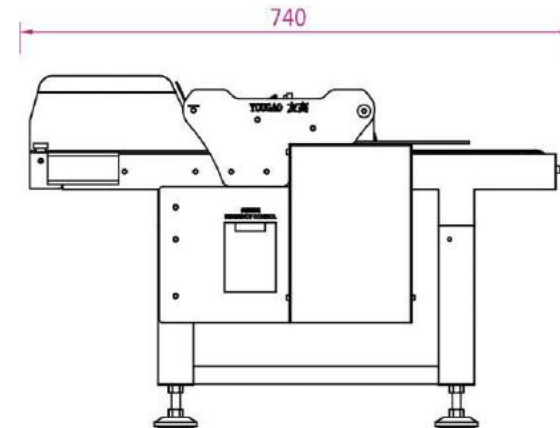
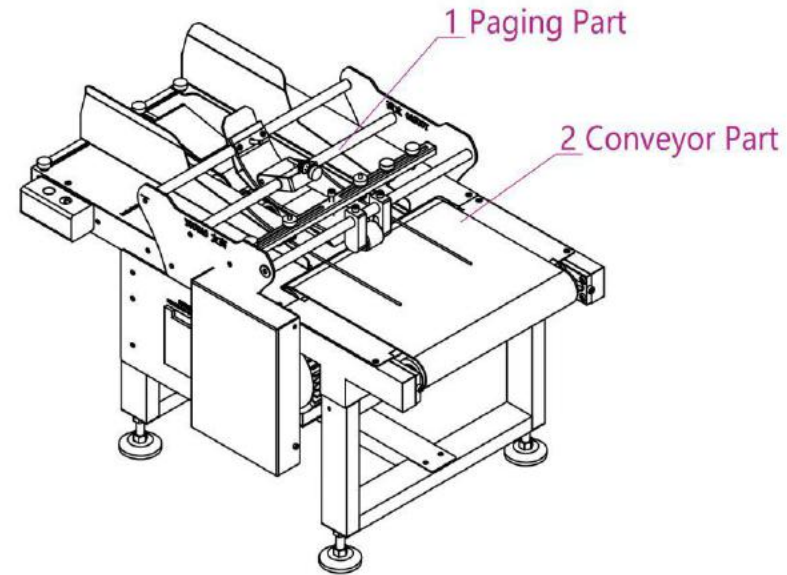



# High Speed Friction Feeder

YG 5005A Desktop Type

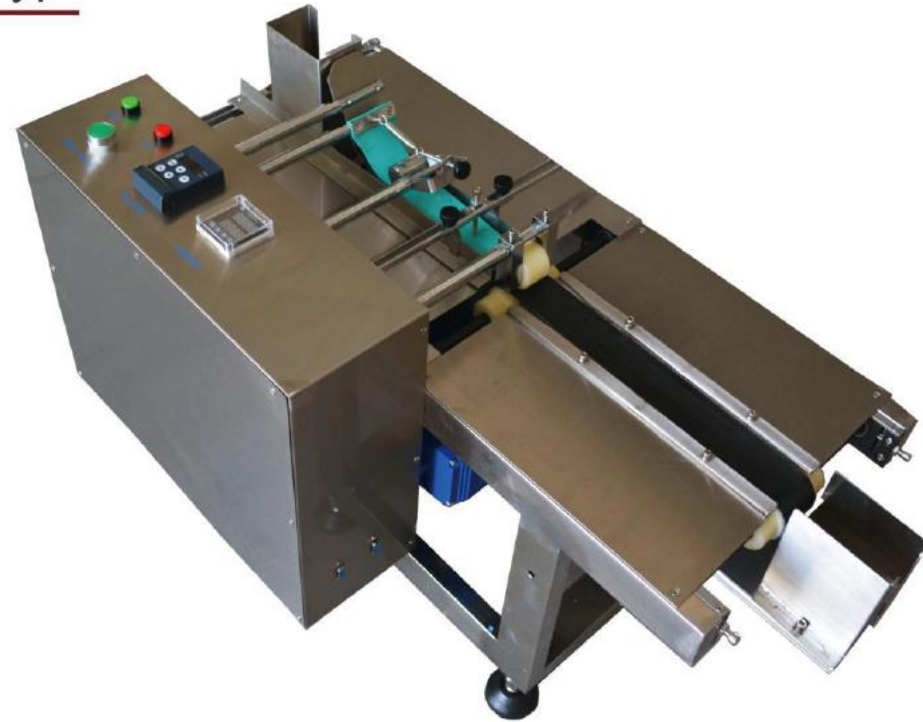

## Product Parameter >>

Type	YG 5005A Desktop Type
Size (mm)	800*340*400mm
Separated Object Size (mm)	Length : 60-320 Width : 30-100 Thickness : 0.02-5
Main Material	Stainless steel
Paging Mode	Friction Type
Voltage	220V
Power	180W
Speed Regulation	Variable Frequency Type
Converter Brand	Schneider
Motor	ZIK
Speed	30-100m/min
Application	Packing Bags:paper box, paper bag, label, paper piece, Card

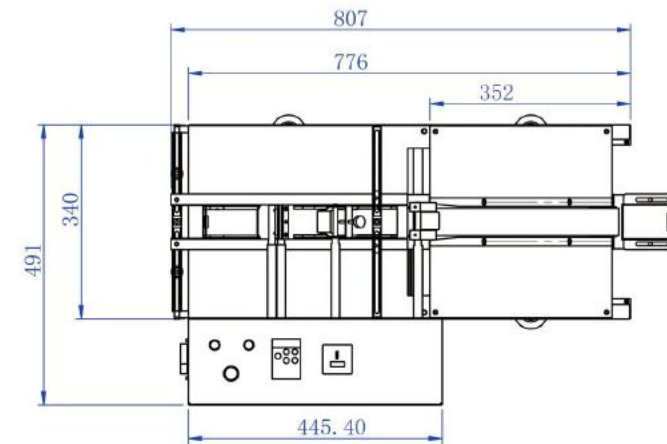
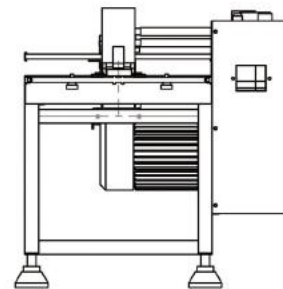
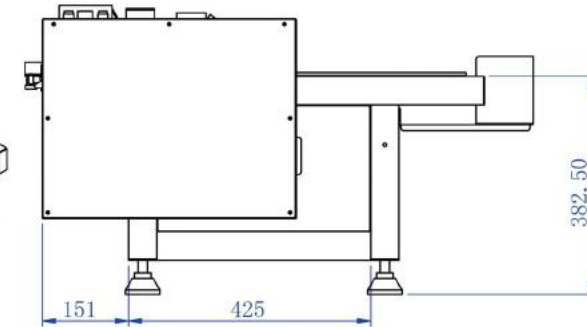
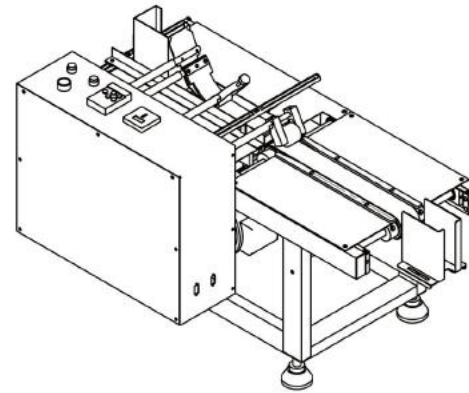

# High Speed Friction Feeder



YG-2012 Series Products

A (Friction Type)

B (Reverse Wheel Type)





## Product Parameter >>

Type	YG-2012A (Friction Standard Type)	YG-2012B (Reverse Wheel Standard Type)
Size (mm)	1420*340/235*750	
Separated Object Size	Length : 60-320mm Width : 70-300mm Thickness : 0.02-5mm	
Main Material	Stainless steel	
Paging Mode	Friction Type	Reverse Wheel Type
Voltage	220V/110V	
Power	180W +90W	
Speed Regulation	Variable Frequency Type	
Converter brand	Schneider	
Motor	ZIK/JSCC	
Application	Packing Bags:Plastic bag, paper box, paper bag, label, paper piece, etc Flake goods:Card	Carton,Card

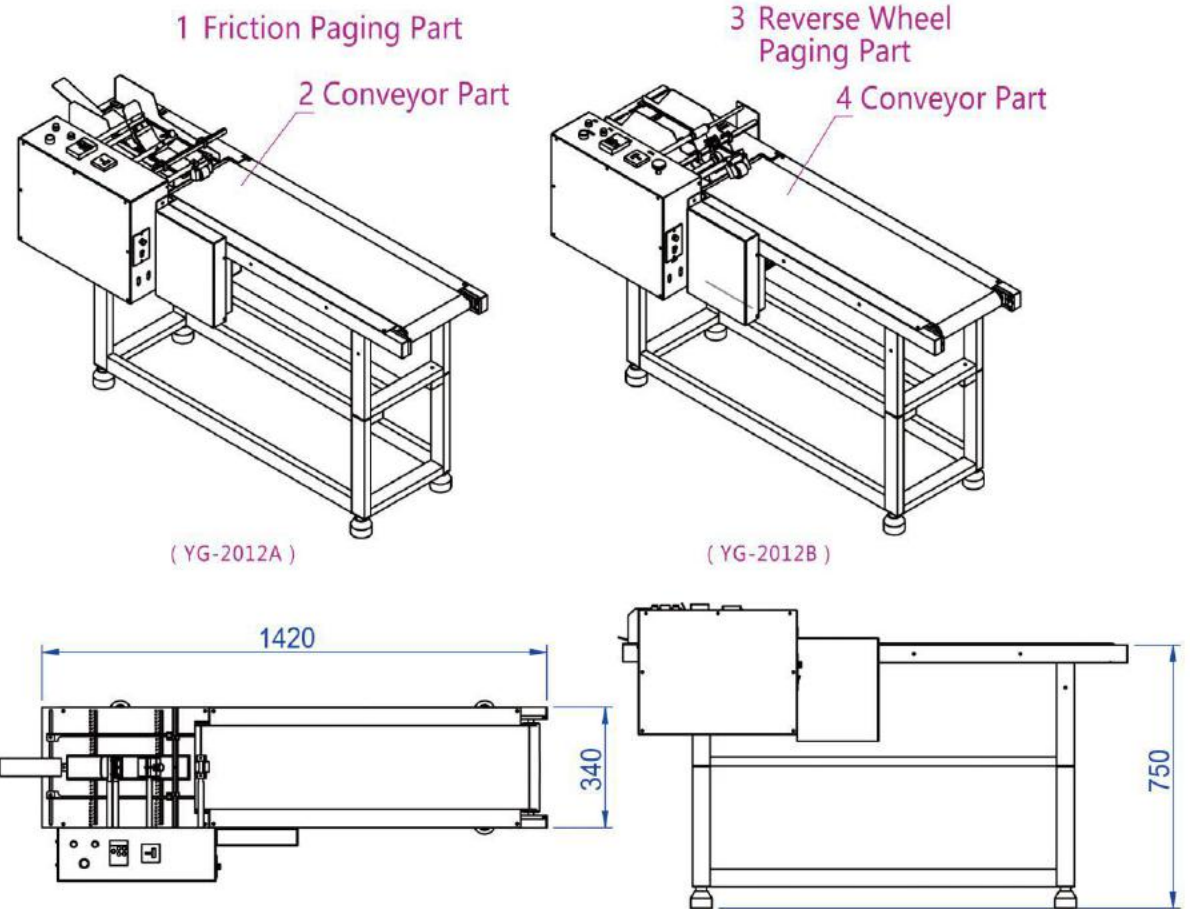

# High Speed Friction Feeder

9000 Series Products  
YOUGAO9011A/-F1/-F2/-F3



# High Speed Friction Feeder



9000 Series Products

YOUGAO9011 AXIAL FLOW ADSORPTION

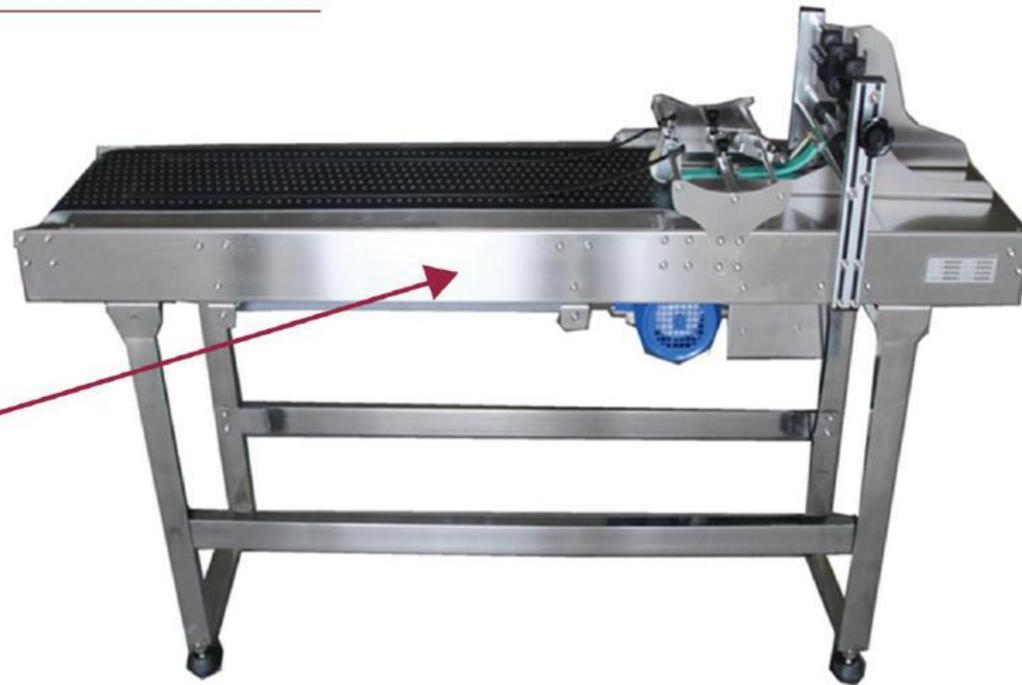

# High Speed Friction Feeder

9000 Series Products  
YOUGAO9011 VACUUM

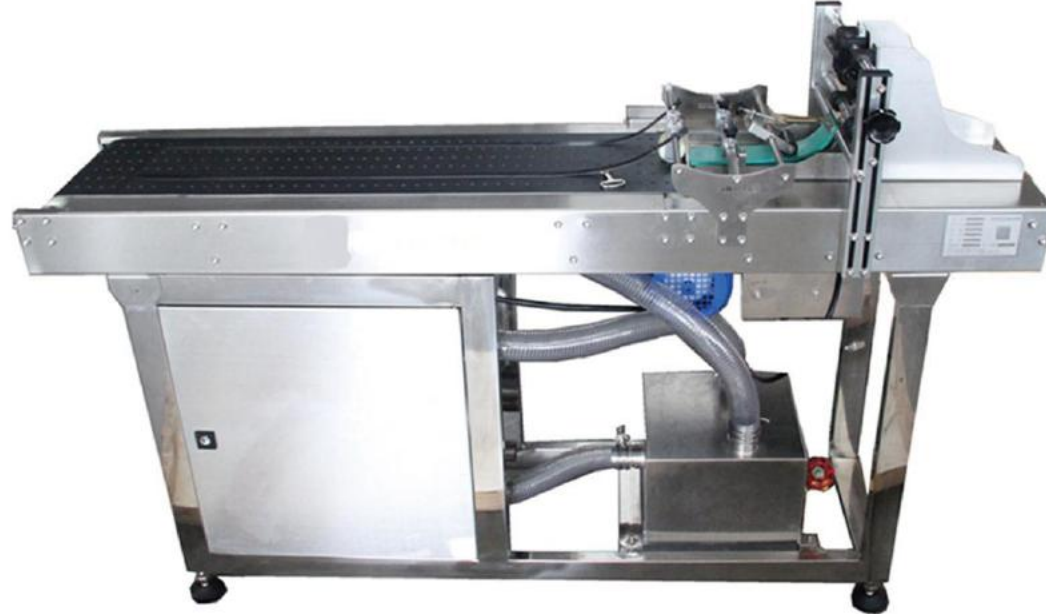
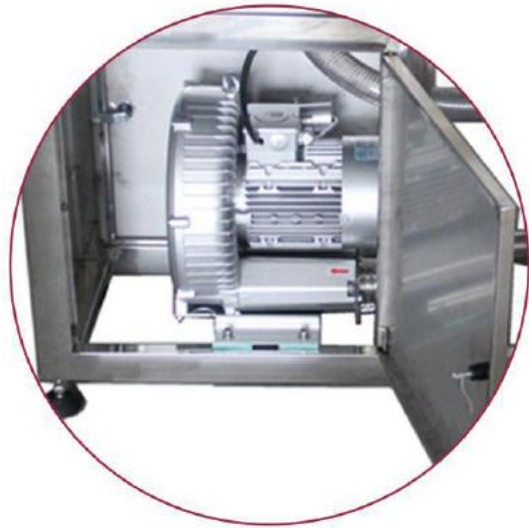



## Product Parameter >>

Type	YOUGAO9011A (Standard Type)	YOUGAO9011A-F1 (Widen Type)	YOUGAO9011A-F2 (Lengthen Type)	YOUGAO9011A-F3 (Lengthen And Widen Type)
Size (mm)	1500*340/235*750	1500*460/360*750	2000*340/235*750	2000*460/360*750
Separated Object Size (mm)	Length: 60-320 Width: 80-300 Thickness: 0.02-5	Length: 60-320 Width: 80-420 Thickness: 0.02-5	Length: 60-500 Width: 80-300 Thickness: 0.02-5	Length: 60-500 Width: 80-420 Thickness: 0.02-5
Main Material	Stainless steel			
Paging Mode	Friction Type			
Voltage	220V			
Power	180W		250W	
Speed Regulation	Variable Frequency Type			
Converter Brand	Schneider			
Motor	ZIK			
Speed	10-110m/min			
Application	Packing Bags: Plastic bag, paper box, paper bag, label, paper piece, etc Flake goods: Card			

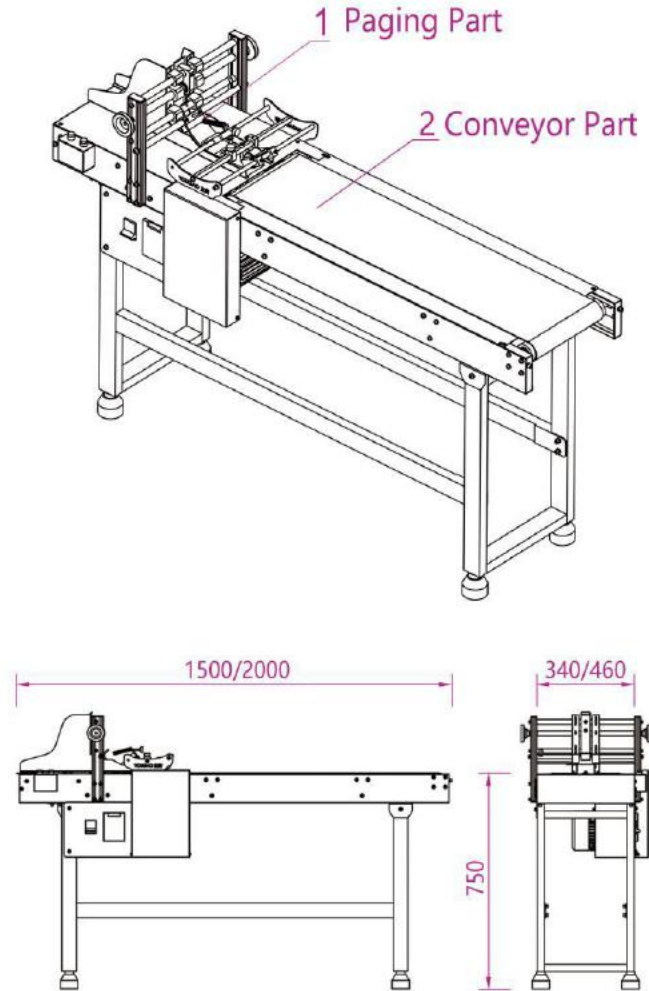



## Product Parameter >>

Type	YOUGAO9011A-F4 (Standard Type)
Size (mm)	2200*600*750
Separated Object Size (mm)	Length: 60-500 Width: 80-560 Thickness: 0.02-5
Main Material	Stainless steel
Paging Mode	Friction Type
Voltage	220V
Power	370W
Speed Regulation	Variable Frequency Type
Converter Brand	Schneider
Motor	ZIK
Speed	10-110m/min
Application	Packing Bags: paper box, paper bag, label, paper piece, Card

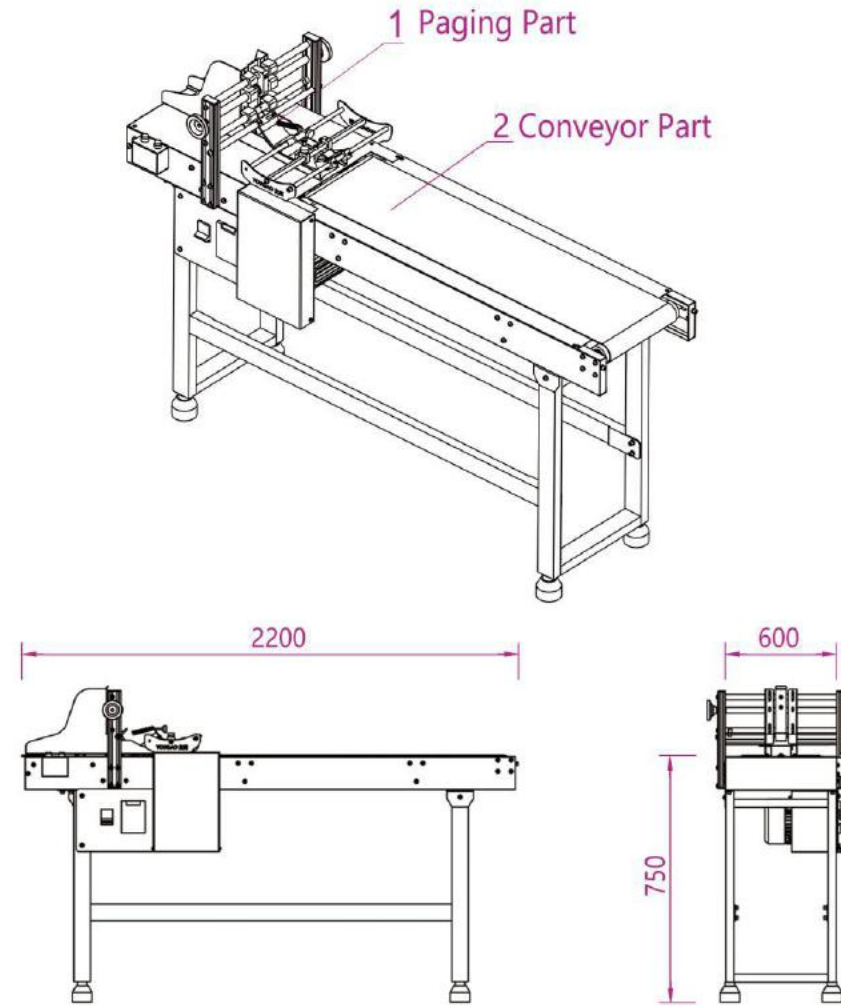

## Product Parameter >>

Type	YOUGAO9011D (Standard Type)
Size (mm)	1500*340/235*750
Separated Object Size (mm)	Length: 60-320 Width: 80-300 Thickness: 0.02-5
Main Material	Stainless steel
Paging Mode	Friction Type
Voltage	220V
Power	180W
Speed Regulation	Variable Frequency Type
Converter Brand	Schneider
Motor	ZIK
Speed	10-110m/min
Application	Packing Bags:paper box, paper bag, label, paper piece, Card

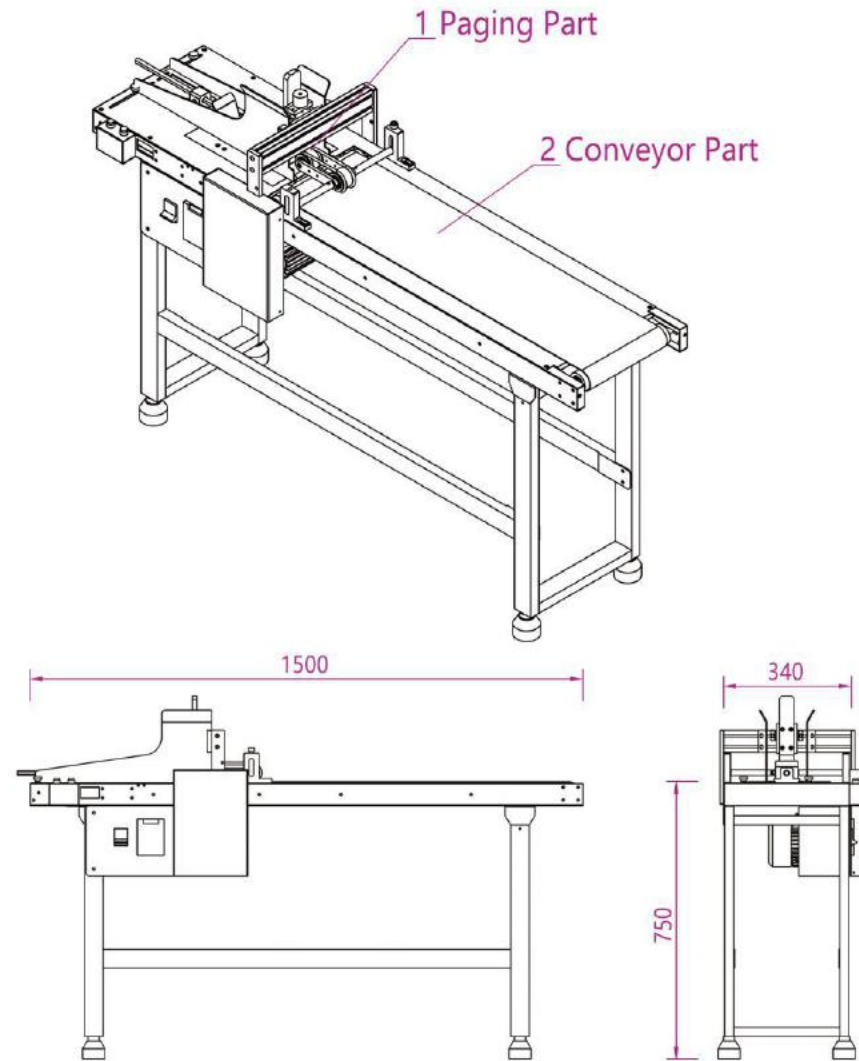

# High Speed Friction Feeder

YG-2011 Series Products

A (Friction Type)

B (Reverse Wheel Type)



## Product Parameter >>

Type	YG-2011A (Friction Standard Type)	YG-2011B (Reverse Wheel Standard Type)
Size (mm)	1420*340/235*750	
Separated Object Size	Length: 60-320mm Width: 70-300mm Thickness: 0.02-5mm	
Main Material	Stainless steel	
Paging Mode	Friction Type	Reverse Wheel Type
Voltage	220V	
Power	180W	
Speed Regulation	Variable Frequency Type	
Converter brand	Schneider	
Motor	ZIK	
Application	Packing Bags: Plastic bag, paper box, paper bag, label, paper piece, etc Flake goods: Card	Carton, Card

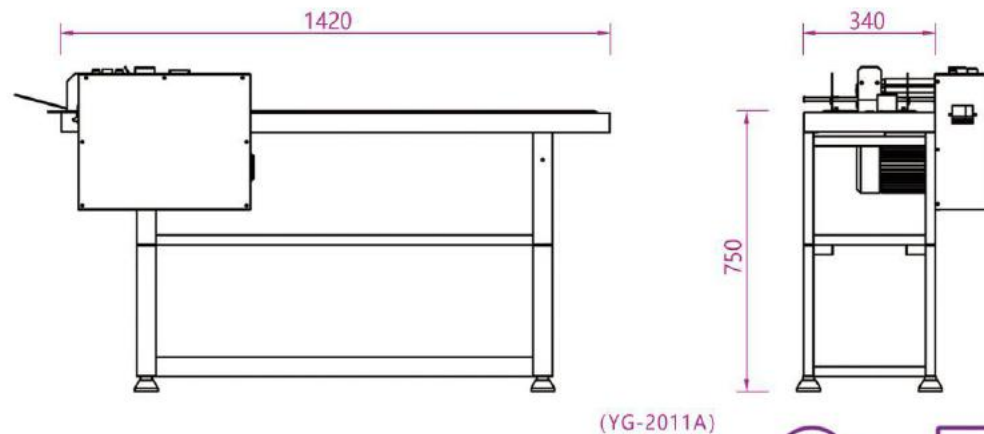
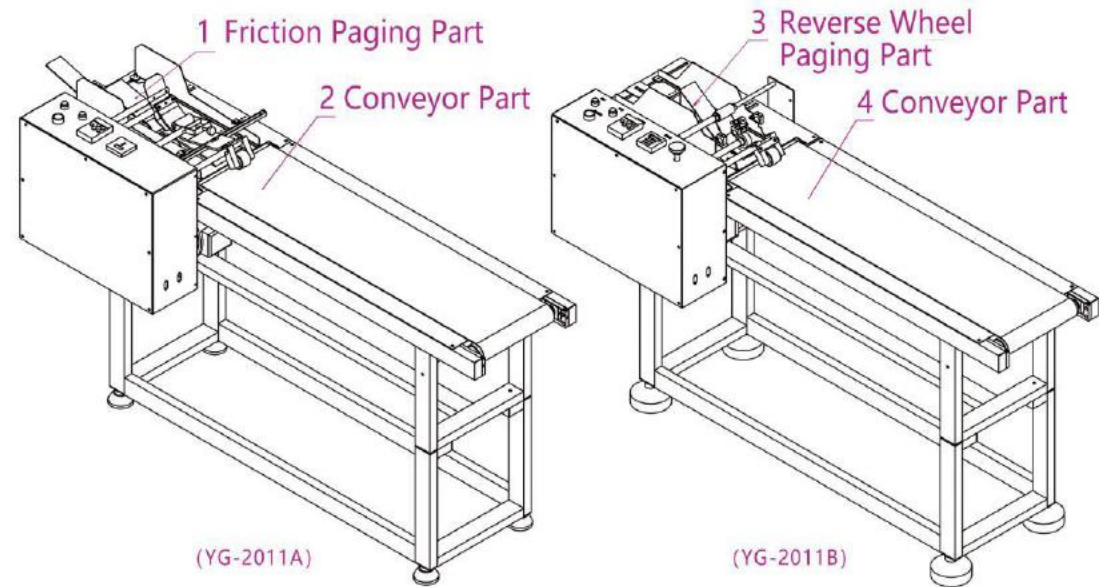



# Automatic Friction Feeder



AIMARK Series Products

A6 / A6PLUS





## Product Parameter >>

Type	A6 (Standard Type)	A6PLUS (Standard Type)
Size (mm)	1240*340/235*750	
Separated Object Size	Length: 60-320mm Width: 70-300mm Thickness: 0.02-5mm	
Main Material	Stainless steel	
Paging Mode	Friction Type	
Voltage	220V	
Power	120W	200W
Speed Regulation	Electronic Type	
Motor	ZD	
Speed	15-50m/min	15-95m/min
Application	Packing Bags: Plastic bag, paper box, paper bag, label, paper piece, etc Flake goods: Card	
Remarks	This model is not suitable for laser marking machine and low-speed coding	

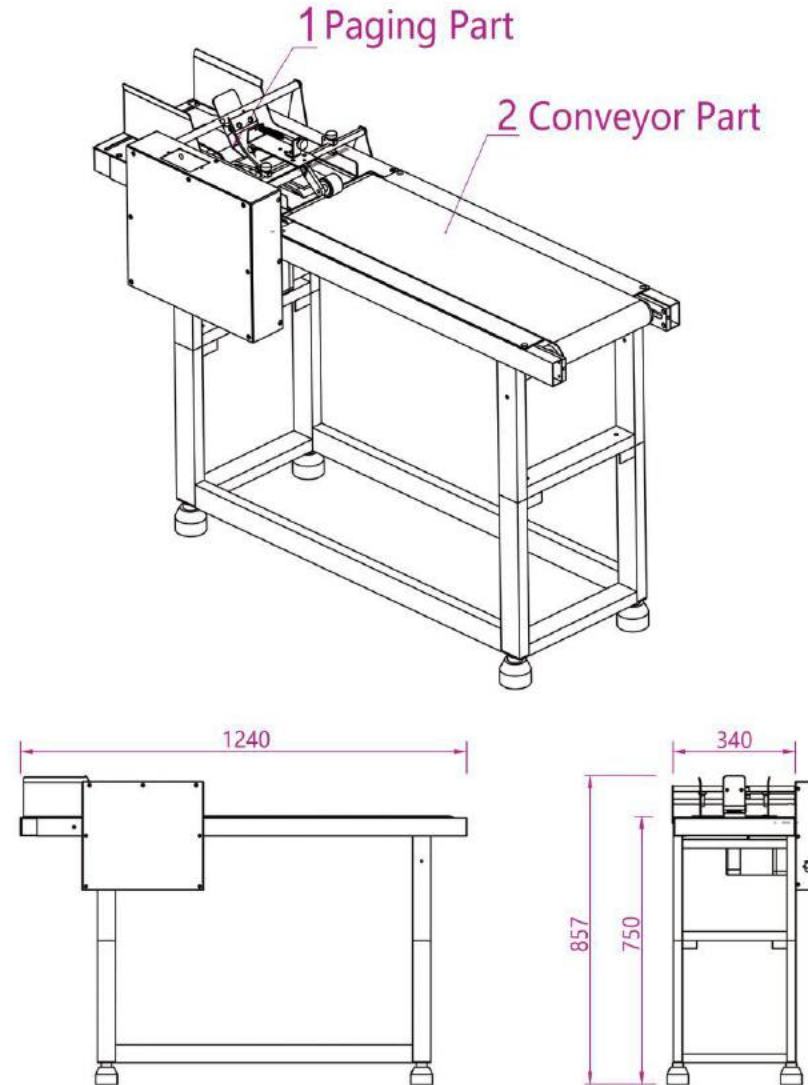

# High Speed Friction Feeder

YG 2002A-F



## Product Parameter >>

Type	YG 2002A-F
Size (mm)	2200*1000/850*750mm
Separated Object Size (mm)	Length : 500-750 Width : 250-370 Thickness : 0.02-5
Main Material	Stainless steel
Paging Mode	Friction Type
Voltage	220V/110V
Power	400W
Speed Regulation	Variable Frequency Type
Converter Brand	Schneider
Motor	CPG
Speed	10-50m/min
Application	Packing Bags:paper box, paper bag, label, paper piece, Card

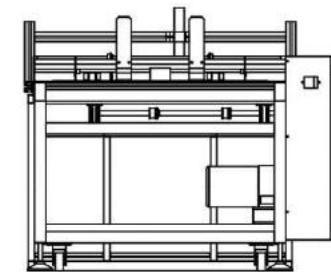
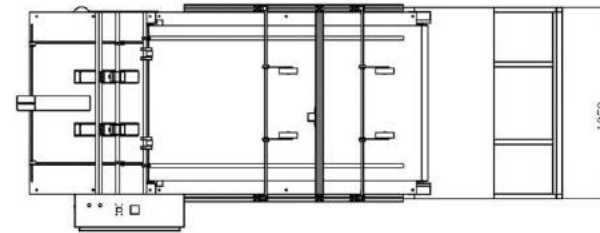
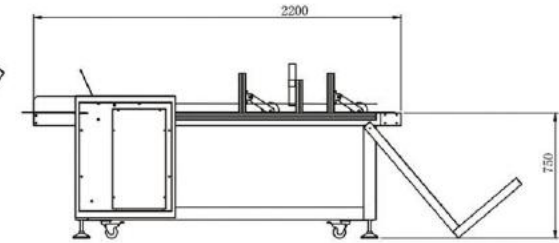
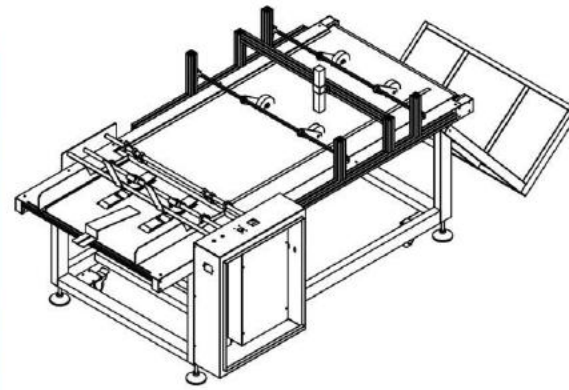

# High Speed Carton Feeder

YG-2023D-F





## Product Parameter >>

Type	YG-2023D-F (Stero Type)
Size (mm)	Conveyor 1:2400*800/650*750 Conveyor 2:1200*800/650*750
Separated Object Size	Length : 300-620mm Width : 350-600mm Thickness : 0.02-5mm
Main Material	Stainless steel
Paging Mode	Friction Type
Voltage	220V/110V
Power	1000W
Speed Regulation	Variable Frequency Type
Converter brand	Schneider
Motor	CPG
Application	Carton

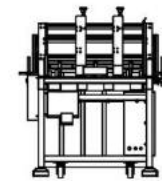
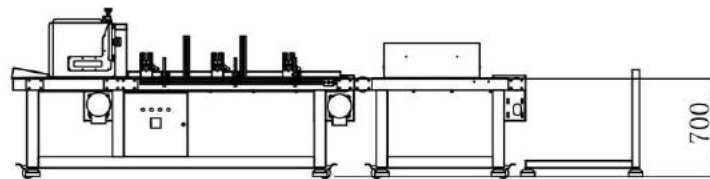
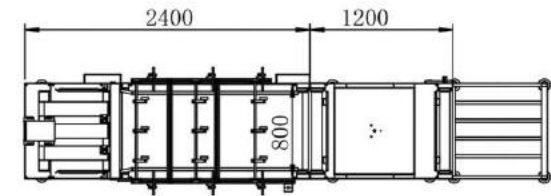
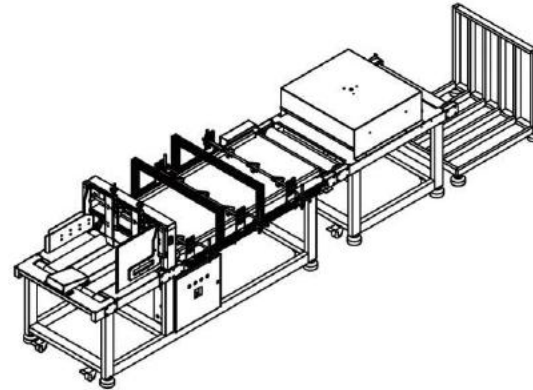



# High Speed Vacuum Suction Feeder



YG-4004A-F

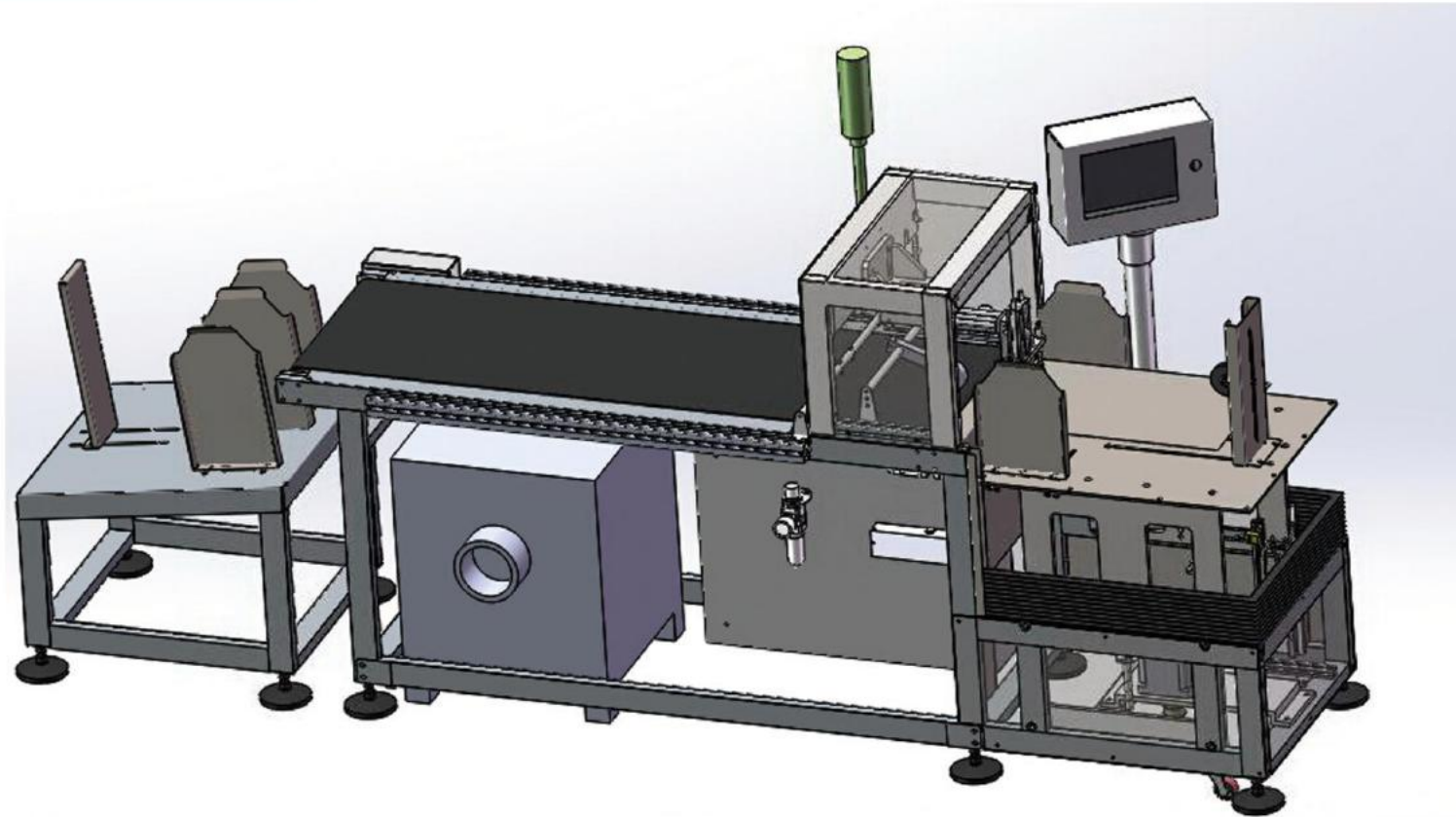

## Product Parameter >>

Type	YG-4004A-F (Vacuum Suction Adsorption Type)
Size (mm)	2550*500*400*750
Separated Object Size	Max:500*300mm Min : 250-250mm Thickness : 0.02-5mm
Main Material	Stainless steel
System	PLC,Touch Screen,Rising system
Voltage	220V/110V
Power	800W
Speed Regulation	Variable Frequency Type
Converter brand	Schneider
Motor	ZD,Garnett
Application	Packing Bags:Plastic bag, paper box, paper bag, label, paper piece, etc Flake goods:Card

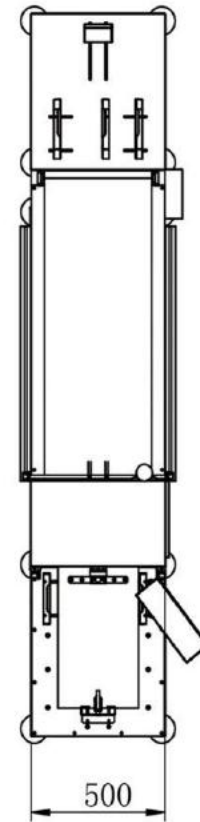
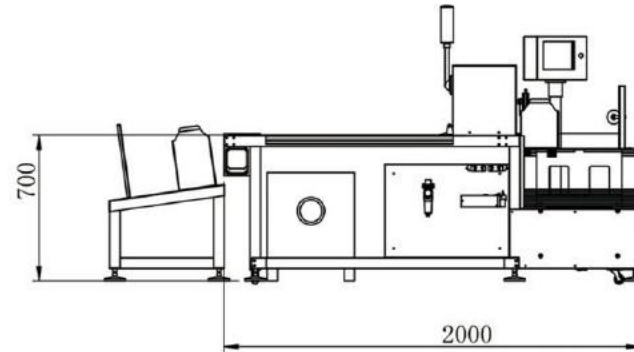
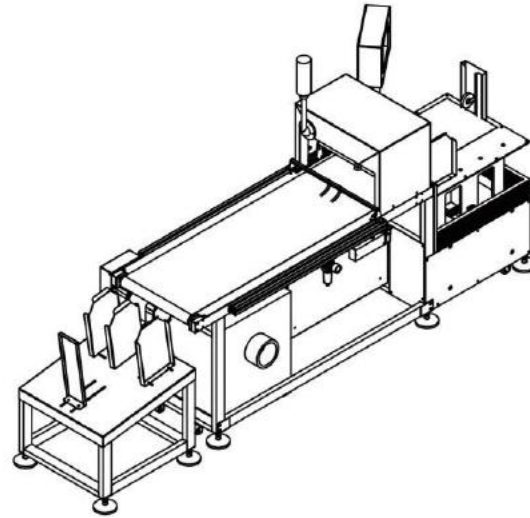

# Bottle bottom coding machine



YG-SP04A



## Product Parameter >>

Type	YG-SP04A
Size (mm)	950*400*850
Main Material	Stainless Steel
Bottle Diameter	20-100mm
Voltage	220V/110V
Power	120W+120W
Speed Regulation	Double Variable Frequency Stepless
Speed	5-30m/min

