

# Shrink Wrapper



## YS-ZB-4255

### Shrink Wrapper

- “One-step ” systems

Model	YS-ZB-4255
Power supply	1P 230V
Maximum power required	3.5KW
Overall machine dimensions	W 750 x L 1230mm
Working plate height (on stand)	920mm
Machine weight	89kg
Sealing area	W 420mm x L 550mm
Maximum product height	200mm
Impulse sealing system	Bottom blade
Maximum roll dimensions	DIA 250mm x W 600mm
Output	4 - 8 pcs/min
Optional	① Roller conveyor ② Scrap rewinder ③ Conveyor

\*Notes: Technical data subject to variations without prior notice  
Output depends on the operator and the type of the package



## YS-ZB-6084

### Shrink Wrapper

- “One-step ” systems

Model	YS-ZB-6084
Power supply	3P 380V
Maximum power required	7KW
Overall machine dimensions	W 950 x L 1940mm
Working plate height (on stand)	920mm
Machine weight	180kg
Sealing area	W 600mm x L 840mm
Maximum product height	200mm
Impulse sealing system	Bottom blade
Maximum roll dimensions	DIA 250 x W 800mm
Output	4-8 pcs/min
Optional	① Roller conveyor

\*notes: Technical data subject to variations without prior notice  
Output depends on the operator and the type of the package



## YS-ZB-5040B

### Pneumatic Shrink Wrapper

- Semiautomatic I-sealer with shrink tunnel 'combo' systems

Model	YS-ZB-5040B
Power supply	3P+N 230V/380V
Maximum power required	5KW
Overall machine dimensions	W 850 x L 2200mm x H 1500
Working plate height (on stand)	930mm
Tunnel entrance dimensions	450 x 230mm
Tunnel length	700mm
Machine weight	270kg
Sealing area	W 500mm x L 400mm
Maximum product height	160mm
Impulse sealing system	Top blade
Maximum roll width	600mm
Compressed air consumption	1 NI/cycle
Compressed air pressure	6 bar
Output	15 pcs/min

\*notes: Technical data subject to variations without prior notice  
Output depends on the operator and the type of the package



## YS-ZB-5040A

### Manual Shrink Wrapper

- Semiautomatic I-sealer with shrink tunnel 'combo' systems

Model	YS-ZB-5040A
Power supply	3P+N 230V/380V
Maximum power required	5KW
Overall machine dimensions	W 850 x L 2200mm x H 1500
Working plate height (on stand)	930mm
Tunnel entrance dimensions	450 x 230 mm
Tunnel length	700mm
Machine weight	270kg
Sealing area	W 500mm x L 400mm
Maximum product height	160mm
Impulse sealing system	Top blade
Maximum roll width	600mm
Compressed air consumption	NO
Compressed air pressure	NO
Output	15 pcs/min

\*notes: Technical data subject to variations without prior notice  
Output depends on the operator and the type of the package



## YS-ZB-1 Shrink Wrapper

Model	YS-ZB-1
Power supply	380V 50Hz 12KW
Air pressure	4kg/cm <sup>2</sup>
Package Size	φ 100mm(max)
Working speed	15pcs/min
Table height	750mm

\*notes: Technical data subject to variations without prior notice  
Output depends on the operator and the type of the package



## YS-ZB-2 Shrink Wrapper

Model	YS-ZB-2
Power supply	380V 50Hz 13KW
Air pressure	4kg/cm <sup>2</sup>
Package Size	φ 100mm(max)
Working speed	15pcs/min
Table height	750mm

\*notes: Technical data subject to variations without prior notice  
Output depends on the operator and the type of the package



## YS-ZB-2Y Shrink Wrapper

- Suitable for round products

\*notes: Technical data subject to variations without prior notice  
Output depends on the operator and the type of the package



## YS-ZB-3 Shrink Wrapper

Model	YS-ZB-3
Power supply	380V 50Hz 13KW
Air pressure	4kg/cm <sup>2</sup>
Conveyor speed	0-18m/min
Working speed	30-45pcs/min
Package Size	L 600mm(max) W 400mm(max) H 500mm(max)
Table height	750mm

\*notes: Technical data subject to variations without prior notice  
Output depends on the operator and the type of the package



## YS-ZB-4 Shrink Wrapper

Model	YS-ZB-4
Power supply	380V 50Hz 13KW
Air pressure	4kg/cm <sup>2</sup>
Conveyor speed	0-18m/min
Working speed	30-45pcs/min
Package Size	L 600mm(max) W 400mm(max) H 500mm(max)
Table height	750mm

\*notes: Technical data subject to variations without prior notice  
Output depends on the operator and the type of the package



## YS-ZB-5A Shrink Wrapper

• The fully automatic I-sealer

Model	YS-ZB-5A	TUNNEL
Power supply	3P+N 380V	3P 230-380V
Maximum power required	1.5KW	7KW
Overall machine dimensions	W 980 x L 1800 x H 1450mm	W 850 x L 1900 x H 1360mm
Working plate height (on stand)	780mm	780mm
Tunnel entrance dimensions		550 x 250mm
Tunnel length		700mm
Machine weight	420kg	130kg
Minimum sealing dimensions	L 90 x W 90mm	
Maximum sealing dimensions	L 550 x W 450mm	
Maximum product height	150mm	
Minimum film width	200mm	
Maximum film width	400mm	
Compressed air consumption	0,5 NI/cycle	
Compressed air pressure	6 bar	
Output	Up to 1700 pcs/h	

\*notes: Technical data subject to variations without prior notice  
Output depends on the operator and the type of the package



## YS-ZB-5B Shrink Wrapper

• The continuous-sealing wrappers

Model	YS-ZB-5B
Power supply	3P 380V
Maximum power required	4 KW
Overall machine dimensions	W 1705 x L 2035 x H 1200mm
Working plate height (on stand)	780mm
Machine weight	420kg
Minimum sealing dimensions	L ∞ x W 90mm
Maximum sealing dimensions	L ∞ x W 420mm
Maximum product height	200mm
Minimum film width	150mm
Maximum film width	650mm
Compressed air consumption	5-6 NI/cycle
Compressed air pressure	6 bar
Output	Variable according to the product

\*notes: Technical data subject to variations without prior notice  
Output depends on the operator and the type of the package

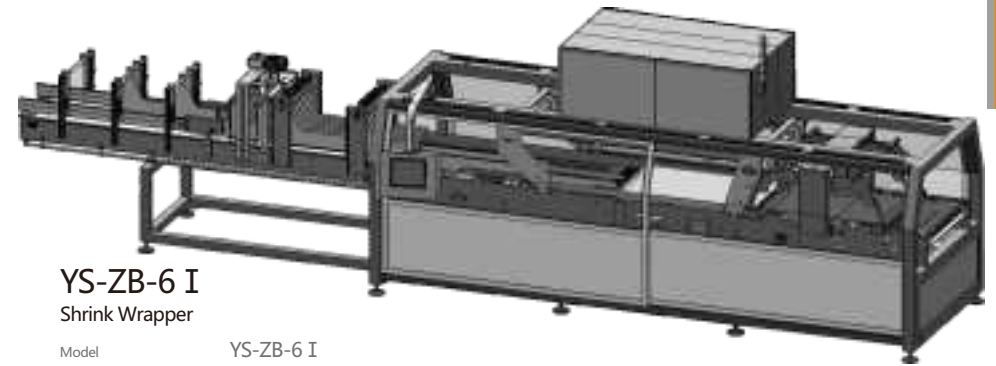
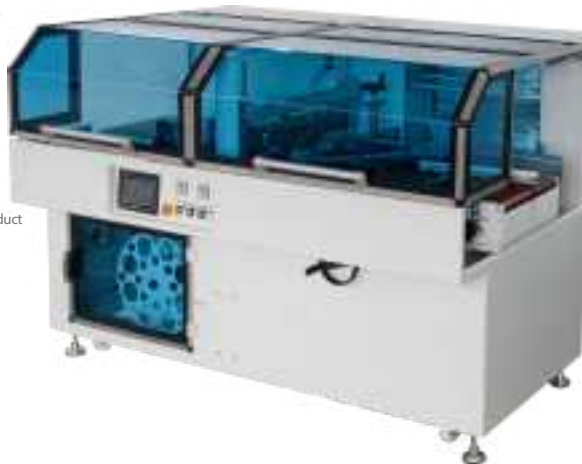

## YS-ZB-6 I Shrink Wrapper

Model	YS-ZB-6 I
Power supply	380V 50Hz 13KW
Air pressure	6kg/cm <sup>2</sup>
Conveyor speed	18m/min
Working speed	45/90pcs/min
Package Size	φ 100mm(max)
Table height	850mm

\*notes: Technical data subject to variations without prior notice  
Output depends on the operator and the type of the package



Stainless Steel

YS-ZB-6ⅡA  
Shrink Wrapper

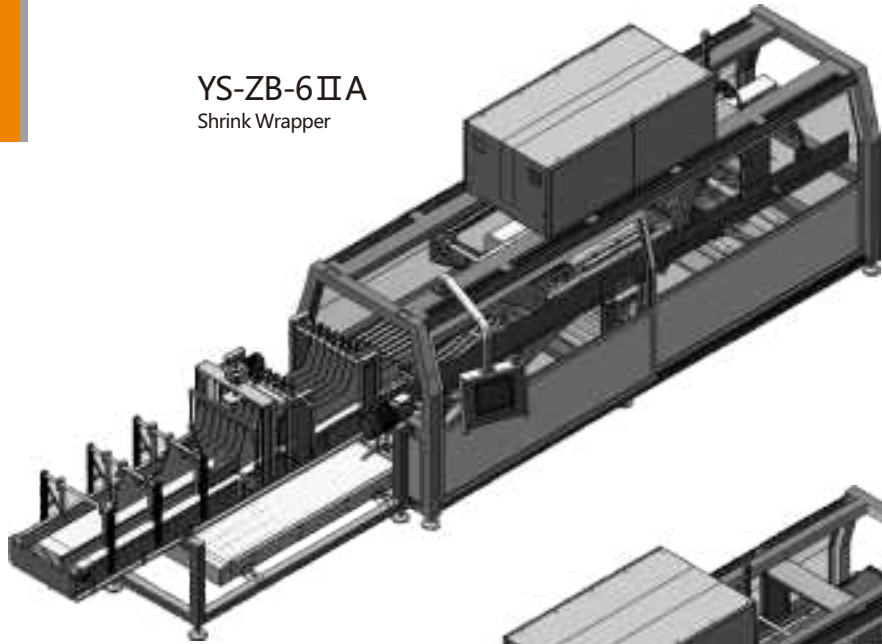

YS-ZB-6ⅡB  
Shrink Wrapper

