

YOUGAO 友高

E5 Egg Coding Machine



E5 Egg Coding Machine



Product Parameter >>

Type	E5 (Standard Type)
Size (L*W*H)	1800*700*1050mm
Function	Whole egg tray printing
Application	5*6/ 6*6 Tray
Control Mode	PLC Control,Touch Screen
Main Material	Stainless Steel
Voltage	220V
Drive Power	Stepper motor drive
Motor Brand	SaiLei
Printing Speed(Printer with reverse function)	7-8s/tray
Printing Speed(Printer without reverse function)	13s/tray

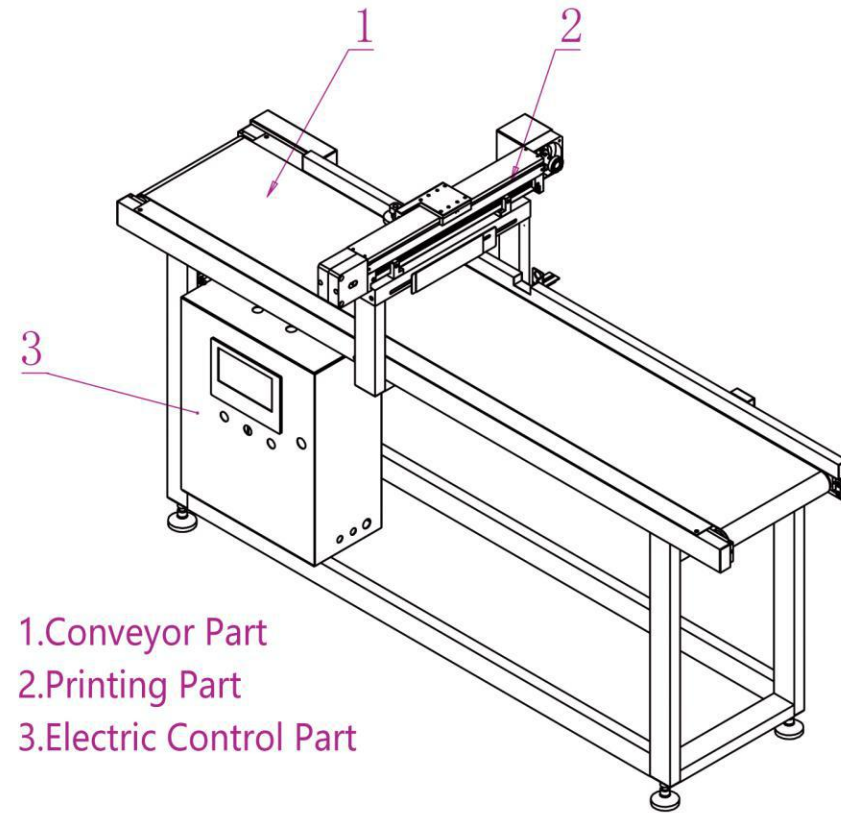

- 1.Conveyor Part
- 2.Printing Part
- 3.Electric Control Part

